

**Valvola overcenter singola, montaggio con C1-C2 flangiate, attacco manometro**  
**Single overcenter valve, gasket mounted: C1-C2 flanged, pressure gauge port**

Rev.03-2010/08

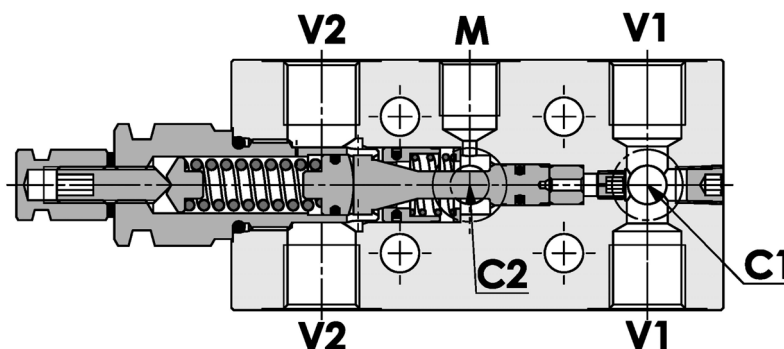
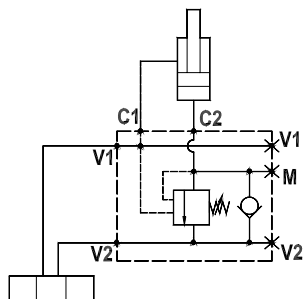

**SPECIFICHE TECNICHE**

**Materiali:** corpo in acciaio, protetto mediante zincatura. I componenti interni sono in acciaio trattato termicamente.

**Portata max.:** 50 l/min

**Taratura max.:** 350 bar

**Rapporto di pilotaggio:** 1 : 4.25 (a richiesta 1 : 8, 1 : 11)

**Regolazione pressione:** mediante vite

**Campo di regolazione pressione:** vedere pag. 02

**TECHNICAL SPECIFICATIONS**

**Materials:** body is steel made, zinc plated. Internal parts are in hardened steel.

**Rated flow:** up to 50 l/min

**Max. setting:** 350 bar

**Pilot ratio:** 1 : 4.25 (1 : 8 and 1 : 11 on request)

**Adjustment means:** leakproof screw adjustment

**Adjustable pressure range:** see page 02

**DIAGRAMMA PERDITE DI CARICO - PRESSURE DROP CURVES**

Viscosità olio 24 mm<sup>2</sup>/sec. (3,5 °E)  
 Temperatura 50 °C

Oil viscosity 24 mm<sup>2</sup>/sec. (3,5 °E)  
 Temperature 50 °C

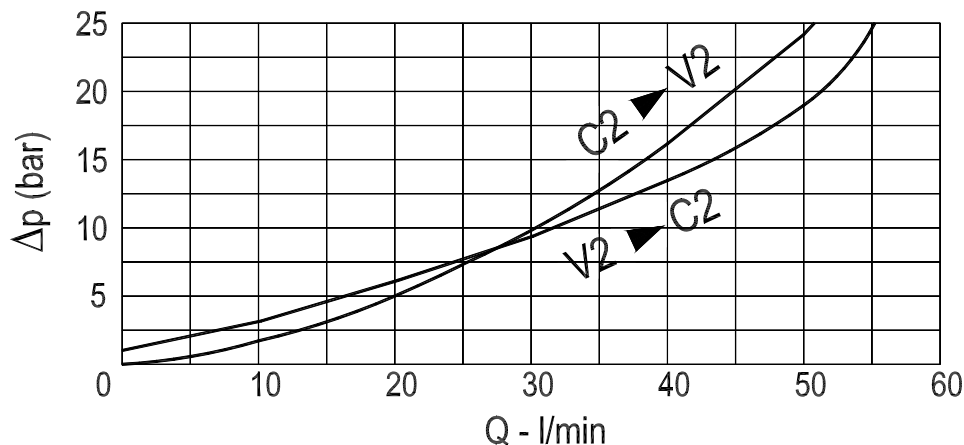

**Valvola overcenter singola, montaggio con C1-C2 flangiate, attacco manometro**  
**Single overcenter valve, gasket mounted: C1-C2 flanged, pressure gauge port**

Rev.03-2010/08

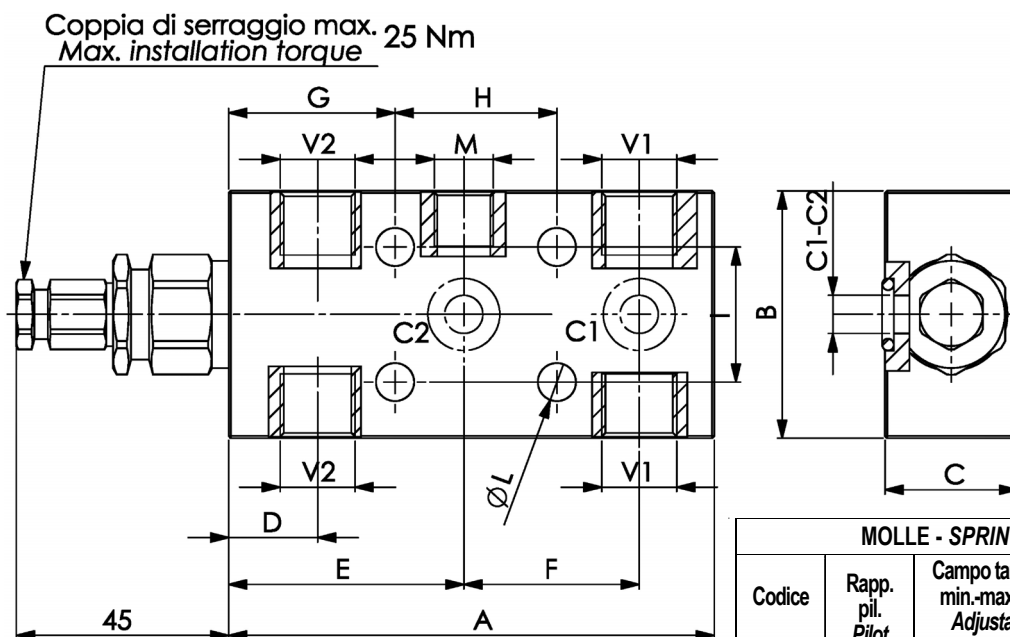

MOLLE - SPRINGS				*
Codice Code	Rapp. pil. Pilot ratio	Campo taratura min.-max. bar Adjustable pressure range bar	Increment. press. bar/giro vite Pressure increase bar/tum	Taratura standard bar Standard setting bar
<b>20</b>	1 : 4.25	60 - 210	70	170
	1 : 8	60 - 220	50	
	1 : 11	60 - 250	90	
<b>35</b>	1 : 4.25	80 - 350	120	280
	1 : 8	100 - 350	85	
	1 : 11	80 - 350	150	

TIPO TYPE	V1-V2	C1-C2	A	B	C	D	E	F	G	H	I	L	O-RING	PESO WEIGHT
	BSPP	mm	mm	mm	mm	mm	mm	mm	mm	mm	mm	mm	mm	Kg
FPO 50 S-1/4"-2F-P-M	1/4"	9	108	55	30	19.5	52	39	37	36	30	8.5	10.77x2.62	1.180
FPO 50 S-3/8"-2F-P-M	3/8"	9	108	55	30	19.5	52	39	37	36	30	8.5	10.77x2.62	1.180
FPO 50 S-1/2"-2F-P-M	1/2"	9	108	65	35	19.5	52	39	37	36	30	8.5	10.77x2.62	1.750

**ESEMPIO DI ORDINAZIONE - ORDERING CODE EXAMPLE**

**F P O 5 0 S 1 / 2 2 F P M 2 0 B \***

\* 1/4 - 1/4" BSPP  
 \* 3/8 - 3/8" BSPP  
 \* 1/2 - 1/2" BSPP  
 Connessioni - Port sizes

\* "20" / "35":  
 Campi di taratura pressione - Adjustable pressure

Guarnizioni - Seals:  
 V=Viton \*  
 Omettere se BUNA-N  
 Omit if BUNA-N

Rapporto di pilotaggio - Pilot ratio  
 Omettere se standard - Omit if standard \*  
 B = 1 : 8, C = 1 : 11